

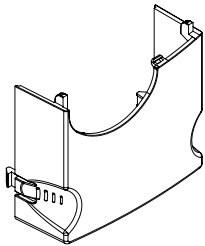

**PowerFlex 4M Replacement Cover**  
**Ersatz-Frontdeckel für PowerFlex 4M**  
**Capot de rechange pour PowerFlex 4M**  
**Coperchio di ricambio per PowerFlex 4M**  
**Tapa de reemplazo del PowerFlex 4M**  
**PowerFlex 4M vervangend afschermkapje**  
**Tampa de Substituição do PowerFlex 4M**

**Installation Instructions**  
**Installationsanleitung**  
**Installation**  
**Installazione**  
**Instalación**  
**Instructies**  
**Instalação**



Frame A  
 Baugröße A  
 Taille A  
 Frame A  
 Tamaño A  
 Frame A  
 Gabinete A

SK-U1-FCVR1-A1

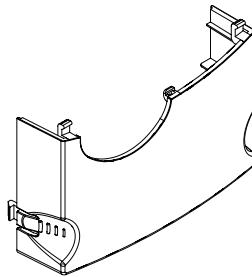

Frame B  
 Baugröße B  
 Taille B  
 Frame B  
 Tamaño B  
 Frame B  
 Gabinete B

SK-U1-FCVR1-B1

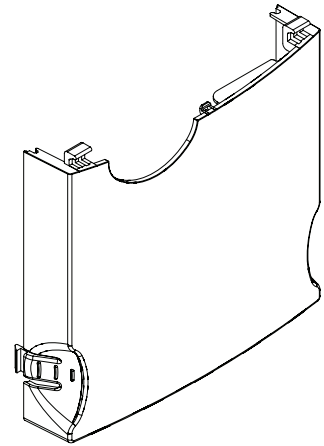

Frame C  
 Baugröße C  
 Taille C  
 Frame C  
 Tamaño C  
 Frame C  
 Gabinete C

SK-U1-FCVR1-C1

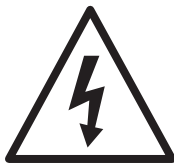
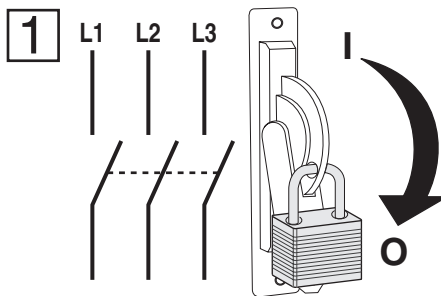

To avoid an electric shock hazard, verify that the voltage on the bus capacitors has discharged before performing any work on the drive. Measure the DC bus voltage at the -DC and +DC terminals on the Power Terminal Block. The voltage must be zero. Darkened LEDs is not an indication that capacitors have discharged to safe voltage levels.

Um die Gefahr eines elektrischen Schlages zu vermeiden, vergewissern Sie sich, dass die Spannung an den Zwischenkreiscondensatoren entladen wurde, bevor Sie Arbeiten am Frequenzrichter durchführen. Messen Sie die DC-Busspannung an den Klemmen -DC und +DC des Klemmenblocks. Die Spannung muss null betragen. Eine dunkle LED-Anzeige bedeutet nicht, dass sich die Kondensatoren auf eine ungefährliche Spannung entladen haben.

Pour éviter tout risque d'électrocution, vérifiez que la tension sur les condensateurs du bus s'est déchargée avant tout intervention sur le variateur. Mesurez la tension du bus c.c. au niveau des bornes -DC et +DC du bornier de puissance. La tension doit être nulle. Le fait que les voyants d'état soient éteints ne signifie pas que les condensateurs ne présentent plus aucune tension dangereuse.

Per evitare il rischio di scosse elettriche, prima di eseguire qualsiasi operazione sull'inverter verificare che la tensione sui condensatori del bus sia stata scaricata. Misurare la tensione del bus CC in corrispondenza dei morsetti -CC e +CC sulla morsettiera. La tensione deve essere pari a zero. Il fatto che i LED del display siano spenti non è un'indicazione dell'avvenuto scaricamento dei condensatori a livelli di tensione sicuri.

Para evitar el peligro de choque eléctrico, verifique que los condensadores de bus estén descargados antes de realizar trabajos en el variador. Mida la tensión del bus de CC en los terminales -DC y +DC del bloque de terminales de alimentación eléctrica. El voltaje debe ser cero. El hecho de que los indicadores LED estén apagados no constituye una indicación de que los condensadores se hayan descargado hasta niveles de voltaje inocuos.

Voorkom elektrische schokken door te controleren of de buscondensatoren zijn ontladen voordat u werkzaamheden aan de drive uitvoert. Meet de spanning op de DC-bus bij de aansluitpunten -DC en +DC op het stroomaansluitblok. De spanning moet nul volt zijn. Een donker LCD-weergavenster en donkere LED's betekenen niet dat de condensatoren ontladen zijn tot een veilig spanningsniveau.

Para evitar risco de choque elétrico, verifique se a tensão do barramento de capacitores foi descarregada antes de realizar qualquer trabalho no inversor. Meça a tensão do barramento de CC nos terminais -CC e +CC, no borne de alimentação. A tensão deve ser zero. Os LEDs escurecidos não são uma indicação de que os capacitores tenham sido descarregados a níveis seguros de tensão.

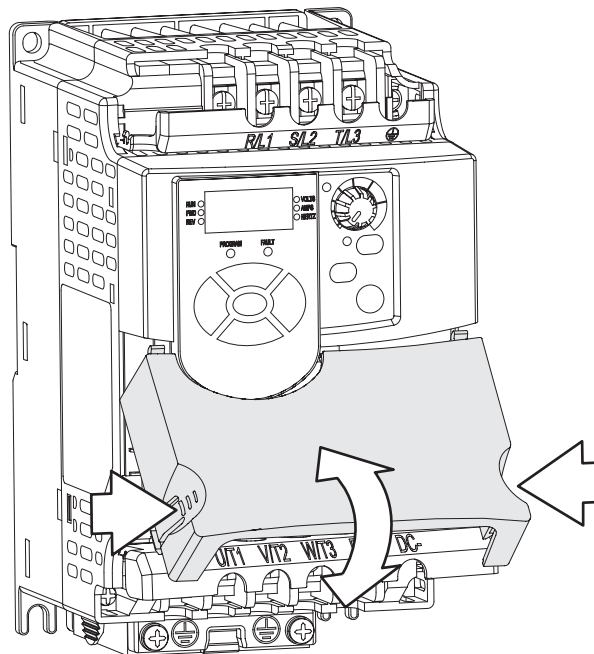

[www.rockwellautomation.com](http://www.rockwellautomation.com)



**Power, Control and Information Solutions Headquarters**

Americas: Rockwell Automation, 1201 South Second Street, Milwaukee, WI 53204-2496 USA, Tel: (1) 414.382.2000, Fax: (1) 414.382.4444

Europe/Middle East/Africa: Rockwell Automation, Vorstlaan/Boulevard du Souverain 36, 1170 Brussels, Belgium, Tel: (32) 2 663 0600, Fax: (32) 2 663 0640

Asia Pacific: Rockwell Automation, Level 14, Core F, Cyberport 3, 100 Cyberport Road, Hong Kong, Tel: (852) 2887 4788, Fax: (852) 2508 1846

**U.S. Allen-Bradley Drives Technical Support**

Tel: (1) 262.512.8176, Fax: (1) 262.512.2222, Email: [support@drives.ra.rockwell.com](mailto:support@drives.ra.rockwell.com), Online: [www.ab.com/support/abdrives](http://www.ab.com/support/abdrives)

